

REESE

INSTALLATION INSTRUCTIONS Product No.

350 LB WEIGHT DISTRIBUTING HITCH WITH ADAPTER KIT

66041

You *can* take it with you.

ELKHART, IN., OAKVILLE, ONT.

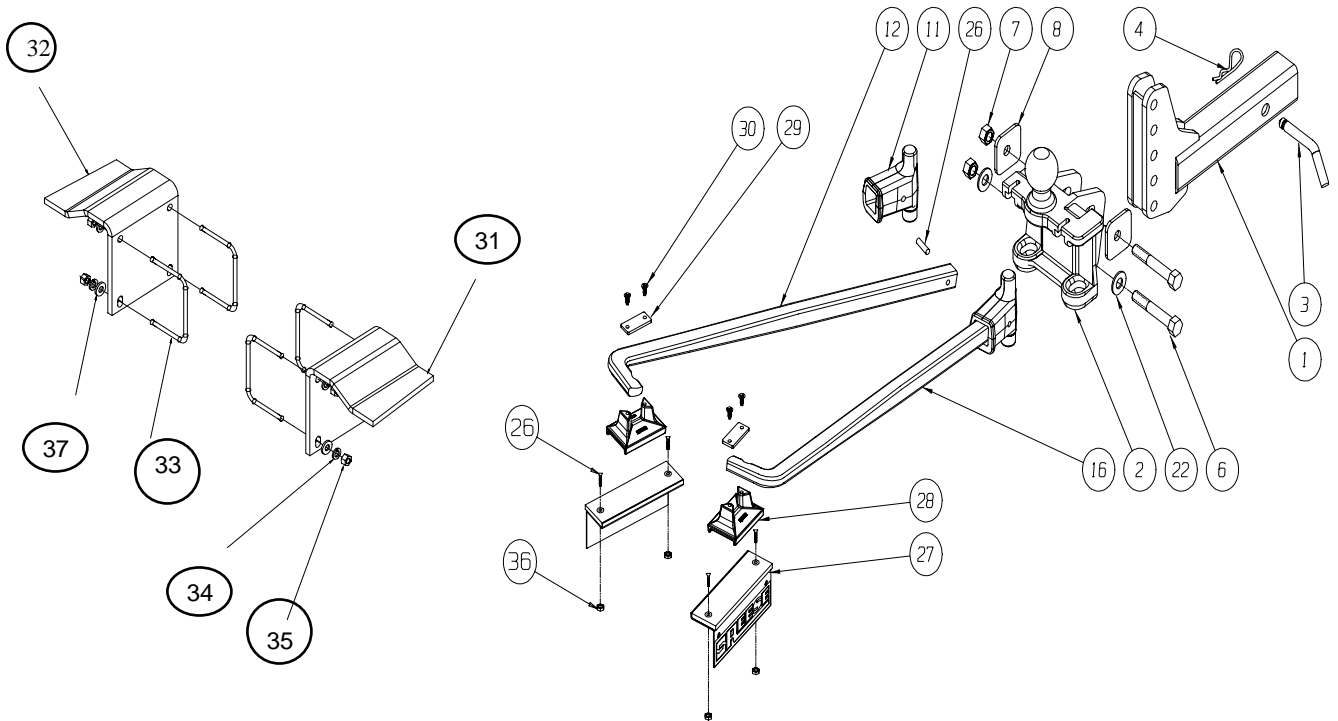

1. MEASURE TRAILER COUPLER HEIGHT- Level trailer and measure from ground to top of ball socket.

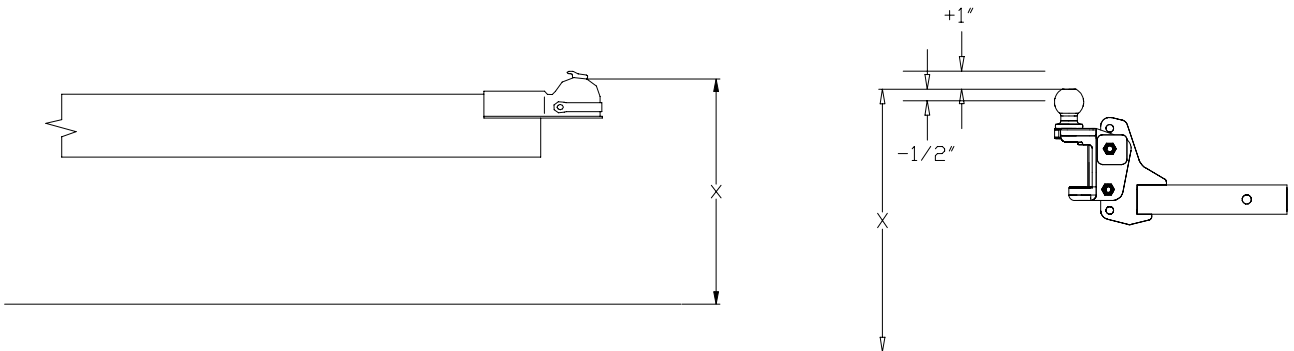

2. ATTACH BALLMOUNT TO HITCH BAR- Insert hitch bar into hitch box and install pull pin and lock in place with spring cotter. Install ball mount onto hitch bar. Move up or down for ball height nearest to coupler height. If halfway between holes, move to the higher position. Install bottom bolt in ball mount with washers on each side and tighten nut enough to hold ball mount position.
3. SET BALLMOUNT ANGLE- With the trailer level, back the tow vehicle to a point where the hitch ball is within a few inches of the coupler. Raise or lower trailer tongue to make the coupler height the same as the ball height. Install the spring bar assemblies in ball mount as shown in illustration, position the ends close to the trailer frame and remove slack by lifting end of bar. Observe the relationship of the bottom of the bar end to the top of the frame. For trailers with light tongue weights (less than 200 lbs.) adjust the ballmount angle so that the bars are approximately 1 to 1.5 inches below the top of the frame.

(OVER)

For Installation Assistance or Technical Help, Call 1-800-758-0869

For trailers with heavier tongue weights (over 200 lbs.) adjust the ballmount angle so that the bars are approximately 2 to 2.5 inches below the top of the frame. Install the top bolt and adjusting washers, rotating the washers so that they are against the shoulder of the ball mount. Torque both top and bottom bolts to 85 lb-ft. Remove the spring bars.

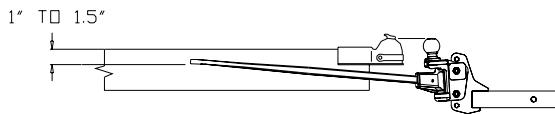

TONGUE WEIGHT LESS THAN 200 LBS

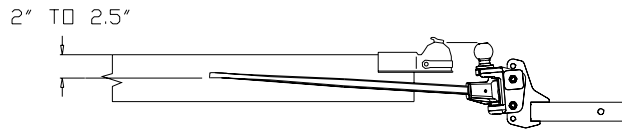

TONGUE WEIGHT MORE THAN 200 LBS

- COUPLE TRAILER TO VEHICLE-** Using the tongue jack, raise the trailer tongue and place coupler over ball, lower the coupler onto the ball, and close the coupler. Drive tow vehicle in a straight line to align trailer and tow vehicle. Assemble slide bracket (28) and retaining plate (29) to spring bars as shown and secure with self tapping screws (30). Reinstall spring bar assemblies in the ball mount as shown in the illustration. Raise the tongue and rear of tow vehicle so that the spring bars can be lifted level with the top of the trailer frame.
- INSTALL THE LEFT SIDE BRACKET -** (For this installation, the left side will correspond to the passenger side of the vehicle). Mark a line on the trailer frame approximately 28 inches from the center of the ball. With the center of the side bracket (31) aligned with this mark, temporarily clamp the bracket to the trailer frame. Position the spring bar over the side bracket (31) to determine if it is centered (adjust the bracket if the spring bar is off center).

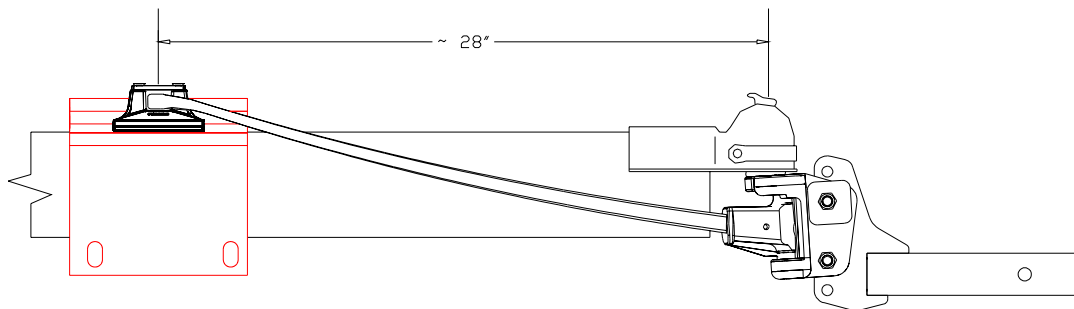

- SECURE THE SIDE BRACKET TO THE FRAME -** Install two 3/8" u-bolts (33) around the trailer frame rail and secure with lockwashers (34), nuts (35), and flat washers (37) on the slotted holes, as shown in the figures below. Torque nuts to 35 ft*lb (It may be necessary to drill 1/2" holes in frame cross members to allow the u-bolts to be positioned around the frame rail).

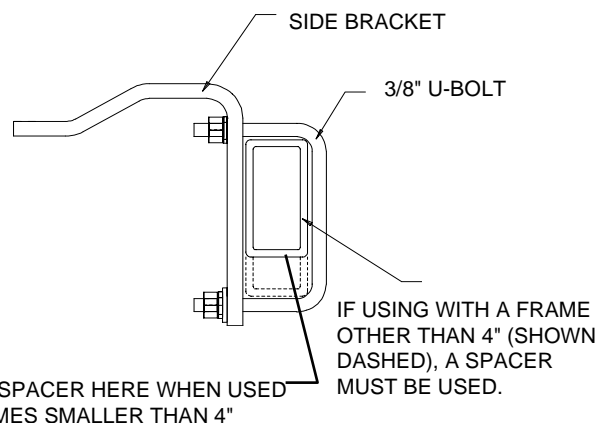
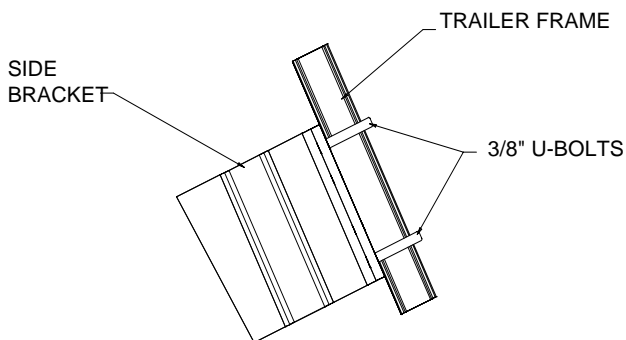

POSITION SPACER HERE WHEN USED WITH FRAMES SMALLER THAN 4"

* NOTE: Be sure to position the u-bolts on the frame as shown in the above diagram.

7. MOUNT THE FRICTION PAD BRACKET - Mark the location of the .172 dia. holes (11/64 drill) on the friction pad (27) as shown in Fig 7A. Place the friction pad on the side bracket (31) as shown in Fig 7B. and drill the .172 dia. holes through both the friction pad and side brackets (Countersink the holes in the friction pad bracket (27) so that the head of the 8-32 screw (26) is approximately 1/16" below the surface). Install the two 8-32 screws (26) and lock nuts (36) as shown in Fig 7C.

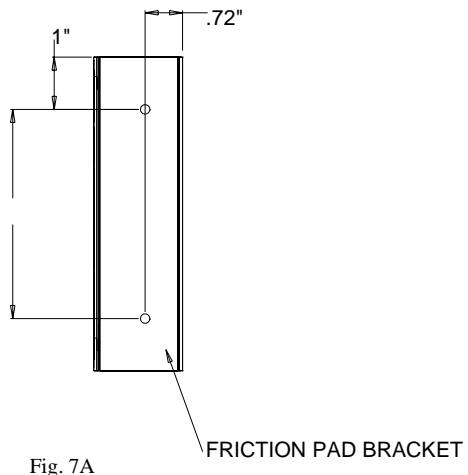

Fig. 7A

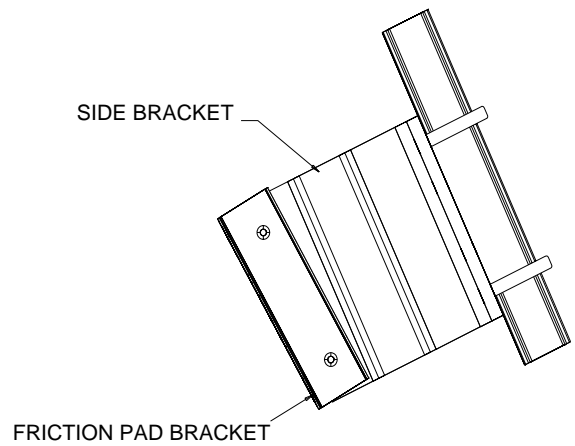

Fig. 7B

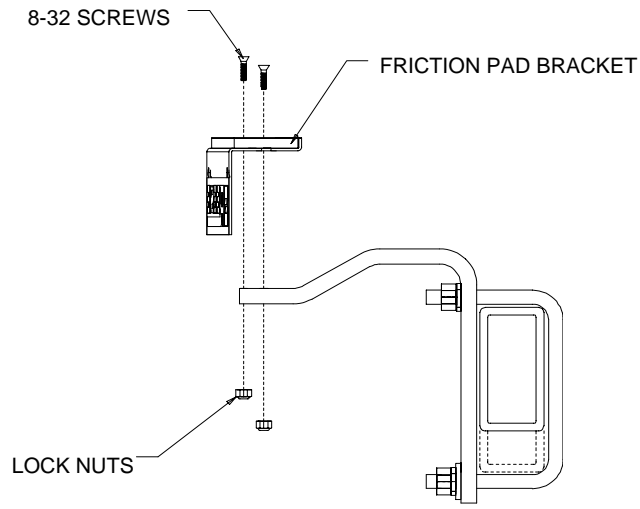

Fig. 7C

8. REPEAT FOR THE OTHER SIDE.

GENERAL TIPS:

- Review the owners' manuals for your towing vehicle and trailer for specific recommendations, capacities, and requirements. NEVER exceed the recommended capacity for any component of the hitch system, trailer, or tow vehicle.
- Good habits for normal driving need extra emphasis when towing. The additional weight affects acceleration and braking, and extra time should be allowed for passing, stopping, and changing lanes.
- Proper trailer loading is important. Heavy items should be placed close to the floor near the trailer axle. The load should be balanced side-to-side and firmly secured to prevent shifting. Tongue weight should be about 10-15 percent of the gross trailer weight for most trailers. Too low a percentage of tongue weight will often produce a tendency to sway.
- Remove the hitch when not towing to prevent contamination of head sockets, reduce chance of striking hitch on driveway ramps or other objects, minimize damage in the event of a rear-end collision.

WARNINGS:

- CAUTION should be used when performing extreme turning maneuvers as turning radius could be reduced when using this system on certain A-Frame trailers.
- LOADED BALL HEIGHT SHOULD NEVER BE GREATER THAN UNCOUPLED BALL HEIGHT. Front wheel overload and loss of rear wheel traction can result, and can lead to unstable handling, reduced braking ability, and a tendency to "jackknife" when turning and braking at the same time.
- DO NOT TOW MULTIPLE TRAILERS. Towing multiple trailers may cause severe instability, loss of control, structural failure, and may result in vehicle accident, property damage, and personal injury. Towing multiple trailers is illegal in many jurisdictions.
- Trailers should NOT be occupied while being towed, under any circumstances.

MAINTENANCE:

- At the beginning of every towing day:
 - * Add a drop of oil at spring bar contact areas with ball mount.
 - * Clean ball and coupler's socket and coat ball lightly with grease.
 - * Check to see that all bolts are properly tightened and hitch pin and clip are securely in place.
 - * Check to see that electrical hookups are in working order, and that safety chains are connected.
- Keep hitch painted to prevent rust and maintain a good appearance (Do not paint over labels).
- Unless specified otherwise by the towing vehicle or trailer manufacturer, tires should be inflated to their maximum recommended pressure.

LIMITED WARRANTY

Hitches - Custom Receivers - Sway Controls

Reese warrants its Hitches, Custom Hitch Receivers, and Sway Controls from date of purchase against defects in material and workmanship under normal use and service, ordinary wear and tear excepted, for the ownership life of the original consumer purchaser.

Reese will replace FREE OF CHARGE any part which proves defective in material or workmanship when presented to any Reese dealer, Reese Warehouse or return to factory. TRANSPORTATION CHARGES PREPAID, at the address below. THIS WARRANTY IS LIMITED TO DEFECTIVE PARTS REPLACEMENT ONLY. LABOR CHARGES AND/OR DAMAGE INCURRED IN INSTALLATION OR REPLACEMENT AS WELL AS INCIDENTAL AND CONSEQUENTIAL DAMAGES CONNECTED THEREWITH ARE EXCLUDED.

Some states do not allow the exclusion or limitation of incidental or consequential damages, so the above limitation or exclusion may not apply to you.

Any damage to the Hitch, Custom Hitch Receiver, and Sway Control as a result of misuse, abuse, neglect, accident, improper installation, or any use violative of instructions furnished by us, WILL VOID THE WARRANTY.

This warranty gives you specific legal rights, and you may also have other rights which vary from state to state. In the event of a problem with warranty service or performance, you may be able to go to a small claims court, or a federal district court.

REESE Products, Inc.
51671 State Road 19-N, Elkhart, IN 46514

REESE Products of Canada, Ltd.
475 Wyecroft Road, Oakville Ontario, Canada L6K2H2