

REESE

You *can* take it with you.

INSTALLATION INSTRUCTIONS DODGE FULL SIZE PICK-UP

PLYMOUTH, MI., OAKVILLE, ONT.

Product No.

45005

SMALL PARTS
PACKAGE 45142

WARNING: DO NOT LUBRICATE THREADS, BOLT FAILURE MAY OCCUR DUE TO OVER TIGHTENING.

WARNING: DO NOT DRILL OR WELD TO THIS HITCH.

IMPORTANT NOTES

USE ONLY REESE SUPPLIED OR APPROVED BOLTS, LOCKNUTS, AND WASHERS TO INSTALL THIS HITCH

NOTE: THIS PRODUCT IS NOT RECOMMENDED FOR USE ON A 1/2 TON VEHICLE.

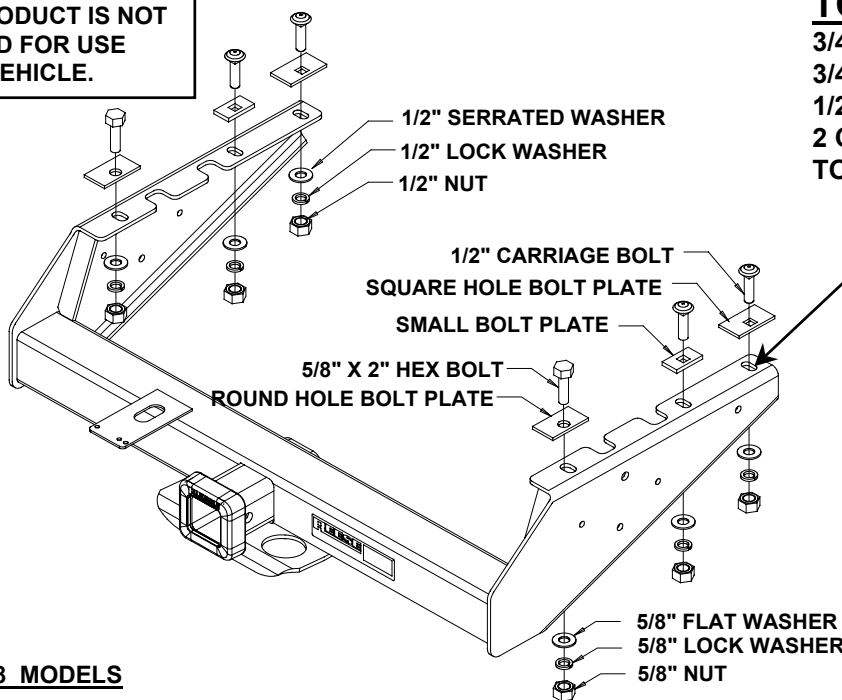

TOOLS REQUIRED

3/4" & 15/16" SOCKET

3/4" & 15/16" WRENCH

1/2", 3/8", & 5/8" DRILLS

2 C-CLAMPS

TORQUE WRENCH

FOR 1994 TO 1998 MODELS

1. Enlarge the second hole from the end of the frame (existing 1/2") to 5/8". Repeat for the other side.
2. Place a 5/8" hex bolt and bolt plate into the second hole from the end of the frame. Repeat for the other side. **NOTE:** Short bed trucks will need to remove the exhaust hanger bracket. It will be replaced later. Loosen the top bumper bracket bolt. Turn the tab that is fastened to it up so it is out of the 1/2" hole in the bottom of the frame.
3. Lift the hitch up and place the rear holes in the bracket over the bolts. Install 5/8" flat washers, lock washers, and nuts.
4. Install 1/2" carriage bolts with bolt plates into the remaining holes in the frame. **NOTE:** Use the small bolt plates for the middle bolts. Install 1/2" serrated washers, lock washers, and nuts. See the diagram above. For short beds, the last hole needs to be drilled. Using the hole in the bracket as a guide, drill a 1/2" hole into the frame. Insert a 1/2" carriage bolt with bolt plate into this hole. Install 1/2" serrated washers, lock washers, and nuts on the remaining bolts.
5. For short beds: Turn the exhaust hanger bracket around so it faces the opposite direction. The rubber bushing should be facing toward the outside. Slide it back on the exhaust pipe rod. Push the exhaust pipe down so there is clearance between the hitch bracket and the tailpipe. Clamp the exhaust bracket in place over the 3/8" diameter hole in the hitch bracket. Drill a 3/8" hole through the exhaust bracket using the hitch bracket as a guide. Fasten the exhaust bracket to the hitch bracket with the bolt and nut that you removed.
6. Torque all 1/2" nuts to 75 ft.*lb.
Torque all 5/8" nuts to 115 ft.*lb.

(OVER)

For Installation Assistance or Technical Help, Call 1-800-758-0869

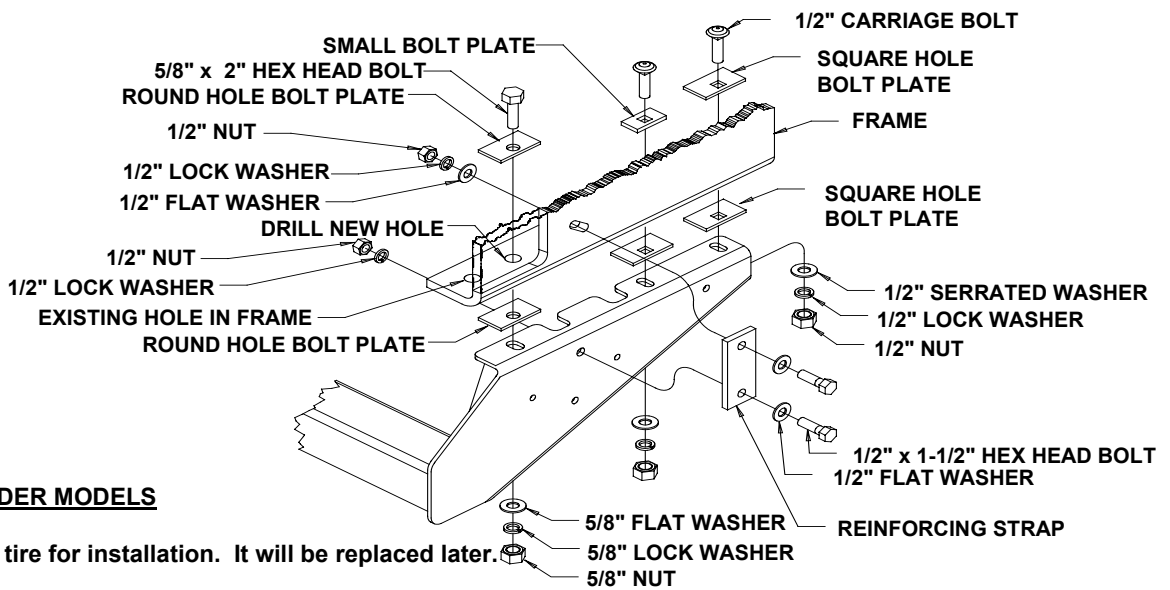

FOR 1993 AND OLDER MODELS

1. Lower the spare tire for installation. It will be replaced later.
2. Align the hitch under the truck so that the 1/2" hole in the side of the hitch bracket is directly below the slotted hole in the frame that the spare tire hanger was hooked into. Clamp the hitch in place with the bolt plates between the frame and the hitch bracket. See the diagram above.
3. Check to see that the reinforcing strap will bolt into the hitch bracket and the slotted frame hole. If it is not aligned, reposition the hitch so it will.
4. Using the holes in the bracket as a guide, drill 1/2" holes into the frame at the forward mounting locations. Drill a 5/8" hole in the rear mounting locations.
5. Insert 1/2" carriage bolts with square hole bolt plates down through the frame in the front holes. NOTE: Use the small bolt plates in the middle holes. Install 1/2" serrated washers, lock washers, and nuts on the bolts. Insert 5/8" hex bolts with round hole bolt plates in the rear holes. Install 5/8" flat washers, lock washers and nuts on the bolts.
6. Install the reinforcing strap with the 1/2" hardware as shown in the diagram.
7. Torque all 1/2" nuts to 75 ft.*lb.
Torque all 5/8" nuts to 115 ft.*lb.
8. Reinstall the spare tire. The "J" hook that was in the frame will need to be moved farther forward on the frame and relocated there. Relocate the spare tire as best suits your truck so as to clear the hitch.

NOTE: To use the adapter bushing with some 2" weight distributing bars, it will be necessary to sand the corners of the bar to get it into the bushing.

For Installation Assistance or Technical Help, Call 1-800-758-0869

THIS PRODUCT COMPLIES WITH SAFETY SPECIFICATION AND REQUIREMENTS FOR THE STATE OF NEW YORK AND VESC REGULATION V-5 FOR CONNECTING DEVICES AND TOWING SYSTEMS. WEIGHT DISTRIBUTING HITCH RATING IS 14000 LB. MAX. GROSS TRAILER WEIGHT AND 1700 LB. MAX. TONGUE WEIGHT. WEIGHT CARRYING HITCH RATING IS 12000 LB MAX GROSS TRAILER WEIGHT AND 1200 LB MAX TONGUE WEIGHT. CONSULT VEHICLE OWNERS MANUAL FOR TOWING RECOMMENDATIONS AND LIMITATIONS.

LIMITED WARRANTY

Reese warrants its Hitches, custom Hitch Receivers, and Sway Controls from date of purchase against defects in material and workmanship under normal use and service, ordinary wear and excepted, for the ownership life of the original consumer purchaser. Reese will replace FREE OF CHARGE any part which proves defective in material or workmanship when presented to any Reese dealer, Reese Warehouse or return to factory. TRANSPORTATION CHARGES PREPAID, at the address below. THIS WARRANTY IS LIMITED TO DEFECTIVE PARTS REPLACEMENT ONLY. LABOR CHARGES AND/OR DAMAGE INCURRED IN INSTALLATION OR REPLACEMENT AS WELL AS INCIDENTAL AND CONSEQUENTIAL DAMAGES CONNECTED THEREWITH ARE EXCLUDED. Some states do not allow the exclusion or limitation of incidental or consequential damages, so the above limitation or exclusion may not apply to you. Any damage to the Hitch, Custom Hitch receiver or Sway Control as a result of misuse, abuse, neglect, accident, improper installation, or any use violative of instructions furnished by us, WILL VOID THE WARRANTY. This warranty gives you specific legal rights, and you may also have other rights which vary from state to state. In the event of a problem Reese warrants its Hitches, Custom Hitch Receivers and Sway Controls from date of purchase against defects in material and workmanship under normal use and service, ordinary wear and tear excepted, for the ownership life of the original consumer purchaser. with warranty service or performance, you may be able to go to a small claims court, a state court, or a federal district court.

Reese Products, Inc.
47774 Anchor Court West
Plymouth, MI 48170

Reese Products of Canada, Ltd.
2351 Winston Park Drive
Oakville, Ontario
Canada L6H6R7