

REESE

You *can* take it with you.

INSTALLATION INSTRUCTIONS

FORD ECONOLINE VAN

Product No.

45001

ELKHART, IN., OAKVILLE, ONT.

SMALL PARTS
PACKAGE 45109

WARNING: DO NOT LUBRICATE THREADS, BOLT FAILURE MAY OCCUR DUE TO OVER TIGHTENING.
WARNING: DO NOT DRILL OR WELD TO THIS HITCH.

IMPORTANT NOTES
USE ONLY REESE SUPPLIED OR APPROVED BOLTS, LOCKNUTS, AND WASHERS TO INSTALL THIS HITCH

TOOLS REQUIRED

9/16" SOCKET
9/16" WRENCH
3/8" DRILL
1/2" DRILL
3/4" SOCKET
TORQUE WRENCH

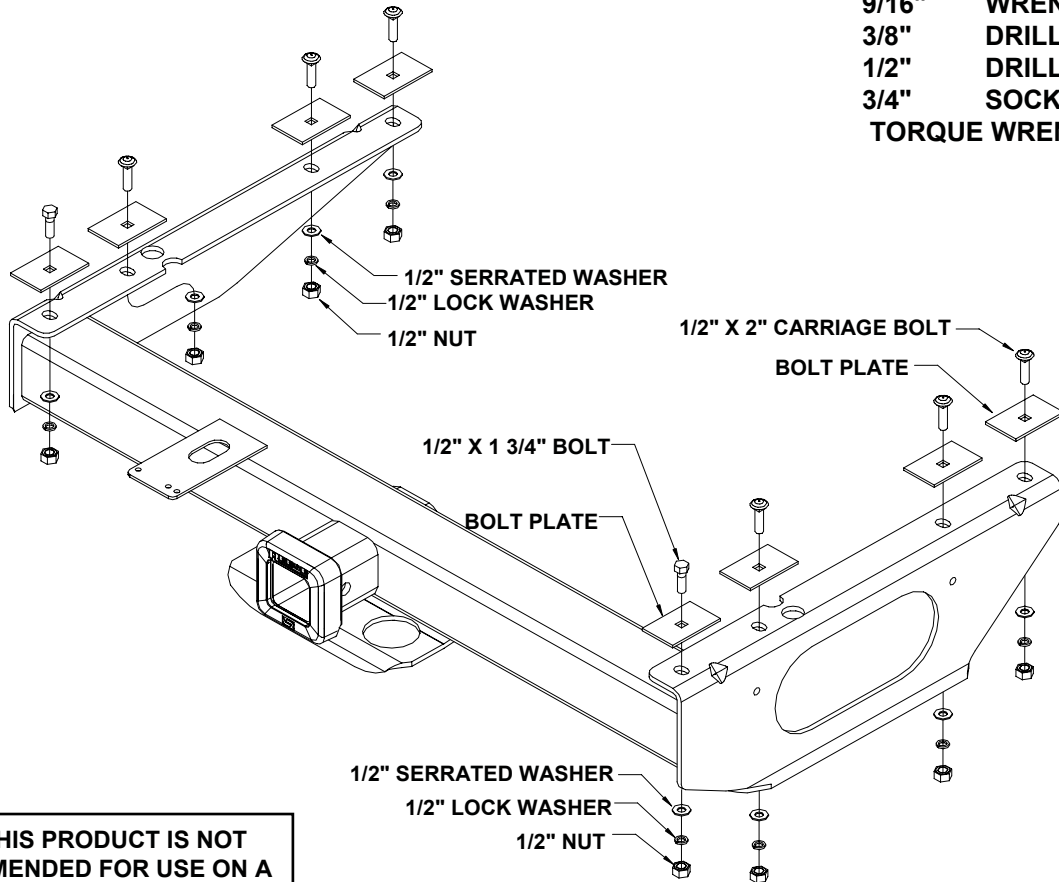

NOTE: THIS PRODUCT IS NOT RECOMMENDED FOR USE ON A 1/2 TON VEHICLE.

1. Lower the spare tire down out of the way during hitch installation. It will be replaced later.
2. Remove the muffler hanger bolt that holds the hanger to the frame. For extended vans, do not remove the bolt.
3. For dual exhaust, remove the hanger from the tailpipes also. Drill a 3/8" hole into the bracket approximately 1" above the welded bolt. Reinstall the muffler bracket using the 1 1/2" long tube spacer provided. Install it into the existing hole in the frame that is above the hole that was used to fasten the bracket. Fasten the bracket with the 3/8" bolt, lock washer, and nut.

(OVER)

For Installation Assistance or Technical Help, Call 1-800-758-0869

4. Some diesel models will require that the exhaust hanger be moved forward to another existing hole in the frame. This is required to obtain clearance between the exhaust hanger and the hitch bracket.
5. Place the hitch up to the frame by sliding the right side bracket over the tailpipes. If this is an extended van, the tailpipes are forward of the bracket and the bracket does not go over the pipes.
6. Place the rear hole in the bracket under the rear hole in the frame. Insert the 1 3/4" bolt with bolt plate down thru the hole. Insert a 2" carriage bolt with bolt plate down thru the second hole in the frame. Install 1/2" serrated washers, lock washers, and nuts on the bolts.
7. Drill out the third hole in the frame to 1/2" diameter. Use the fourth hole in the bracket as a guide and drill a 1/2" hole into the frame. Remove any wires in the frame.
8. Insert 1/2" carriage bolts with bolt plates down thru the frame and into the brackets. Install 1/2" serrated washers, lock washers, and nuts on the bolts.
9. Torque the 3/8" nut to 35 ft.*lb
Torque the 1/2" nuts to 75 ft.*lb.
Reinstall the spare tire.

NOTE: To use the adapter bushing with some 2" weight distributing bars, it will be necessary to sand the corners of the bar to get it into the bushing.

For Installation Assistance or Technical Help, Call 1-800-758-0869

THIS PRODUCT COMPLIES WITH SAFETY SPECIFICATION AND REQUIREMENTS FOR THE STATE OF NEW YORK AND VESC REGULATION V-5 FOR CONNECTING DEVICES AND TOWING SYSTEMS. WEIGHT DISTRIBUTING HITCH RATING IS 14000 LB. MAX. GROSS TRAILER WEIGHT AND 1700 LB. MAX. TONGUE WEIGHT. WEIGHT CARRYING HITCH RATING IS 12000 LB MAX GROSS TRAILER WEIGHT AND 1200 LB MAX TONGUE WEIGHT. CONSULT VEHICLE OWNERS MANUAL FOR TOWING RECOMMENDATIONS AND LIMITATIONS.

LIMITED WARRANTY

Reese warrants its Hitches, custom Hitch Receivers, and Sway Controls from date of purchase against defects in material and workmanship under normal use and service, ordinary wear and excepted, for the ownership life of the original consumer purchaser. Reese will replace FREE OF CHARGE any part which proves defective in material or workmanship when presented to any Reese dealer, Reese Warehouse or return to factory. TRANSPORTATION CHARGES PREPAID, at the address below. THIS WARRANTY IS LIMITED TO DEFECTIVE PARTS REPLACEMENT ONLY. LABOR CHARGES AND/OR DAMAGE INCURRED IN INSTALLATION OR REPLACEMENT AS WELL AS INCIDENTAL AND CONSEQUENTIAL DAMAGES CONNECTED THEREWITH ARE EXCLUDED. Some states do not allow the exclusion or limitation of incidental or consequential damages, so the above limitation or exclusion may not apply to you. Any damage to the Hitch, Custom Hitch receiver or Sway Control as a result of misuse, abuse, neglect, accident, improper installation, or any use violative of instructions furnished by us, WILL VOID THE WARRANTY. This warranty gives you specific legal rights, and you may also have other rights which vary from state to state. In the event of a problem Reese warrants its Hitches, Custom Hitch Receivers and Sway Controls from date of purchase against defects in material and workmanship under normal use and service, ordinary wear and tear excepted, for the ownership life of the original consumer purchaser. with warranty service or performance, you may be able to go to a small claims court, a state court, or a federal district court.

Reese Products, Inc.
51671 State Road 19-N
Elkhart, IN 46514

Reese Products of Canada, Ltd.
475 Wycroft Road
Oakville, Ontario
Canada L6K2H2