

# TOWING PRODUCTS

## INSTALLATION INSTRUCTIONS BASE RAIL MOUNTING KIT '04 & UP FORD F-150 5.5', 6' & 8' BEDS

30080

### DEALER/INSTALLER:

- (1) Provide this Manual to end user.
- (2) Physically demonstrate procedures in this Manual to end user.
- (3) Have end user demonstrate that he/she understands procedures.

### END USER:

- (1) Read and follow this Manual every time you use Hitch.
- (2) Save this Manual for future reference.
- (3) Pass on copies of Manual to any other user or owner of Hitch.

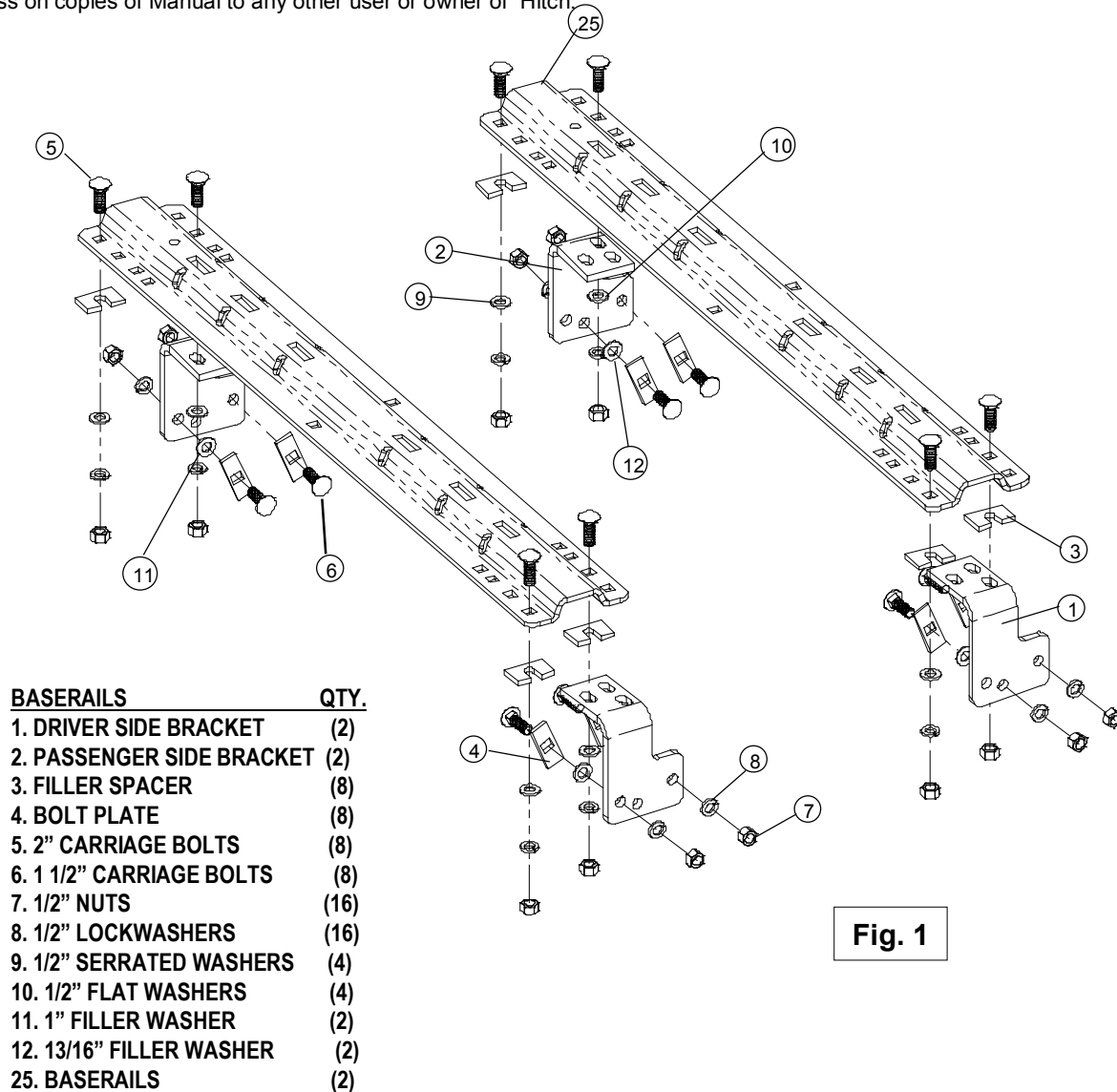



Fig. 1

For Installation Assistance or Technical Help, Call 1-888-521-0510

**TOOLS**



- |                                         |                               |
|-----------------------------------------|-------------------------------|
| 3/16" drill                             | 3/4" Socket & Open End Wrench |
| 17/32" drill                            | 100 lb-ft Torque Wrench       |
| 1" drill (Some Dodge applications only) | "C" Clamps                    |

1. The following instructions should be used to mount the 5th wheel. Care and attention to detail will ensure a quick quality installation. Check parts against parts list to become familiar with parts in kit. (See Fig. 1)
2. Raise rear of truck high enough to allow jack stands to be placed under rear spring hanger bracket of truck. This will provide maximum room to install the 5th wheel brackets.

 **WARNING:**



**If the truck is raised, be sure that the truck is properly blocked and restrained to prevent the truck from falling. Failure to do so may result in the truck suddenly falling, causing death or serious injury.**

3. Do not install mounting rails over plastic bed liners. Plastic bed liners must be cut out of the way. Base rails may be installed on spray in liner. **Note:** Consult installer for recommended curing time.
4. Use only CEQUENT TOWING PRODUCTS supplied bolts, nuts, and washers to install this kit. All bolts are grade 5 and nuts are grade 5 unless specified otherwise.
5. Specific instructions for most commonly used vehicles are included. If these instructions do not apply to your vehicle, be sure that each end of each base rail is connected to the vehicle frame. Each frame bracket must be bolted to the vehicle frame with two bolts, unless optional weld is used.

 **CAUTION:** 

**These instructions are guidelines only. Actual installation is the responsibility of the installer and the owner. Always measure truck and trailer before installing hitch to be sure that there is clearance at the cab and at the bumper to allow for turns.**

6. To prevent the trailer from hitting the cab with the trailer turned 90°, the center of the hitch should be at least 52" from the back of the cab when using a long bed truck. (Actual distance required will depend on trailer width and king pin location.) Short bed (Minimum 38" from back cab to axle center line) trucks require a minimum of a 13" extended pin box or a SIDEWINDER Pinbox Coupler for regular maneuvers and do not apply. **DO NOT INSTALL ON OR ATTEMPT TO TOW WITH A TRUCK HAVING LESS THAN A 6' BED WITHOUT A SIDEWINDER PINBOX COUPLER INSTALLED ON THE TRAILER.**
7. Measurements are given from Rear Edge of truck bed to rear edge of the base rail closest to the Rear Edge of truck for most vehicle applications (See Fig. 2).
8. Center hitch between fender wells and make sure rails are square. Adjust position of rails until both diagonal measurements are the same. This should allow installation of a gooseneck or other 5th wheels to these rails (See Fig. 2).

 **CAUTION:** 

**Check for obstructions before drilling. Failure to do so could result in damaged fuel or brake lines, structural members, etc. CEQUENT TOWING PRODUCTS does its best to communicate tow vehicle manufacturer changes; however, it is ultimately the responsibility of the installer to prevent damage due to installation.**

9. Drill 8 holes identified in Fig. 2. (Hole location will vary for individual vehicle applications.) Drill all holes with 3/16" drill and enlarge them with a 17/32" drill. Always use sharp drill bits. A 3/16" pilot hole will greatly speed drilling larger holes. Install 1/2" carriage bolts into holes. Install 5/16" thick slotted spacer above or below bed to fill corrugations in bed floor.
10. Install mounting brackets onto carriage bolts with the long brackets on forward bolts and short brackets on rearward (long and short brackets can be interchanged as needed). Secure bolts through mounting brackets with serrated washers, lock washers, and hex nuts. Secure the other four bolts through the bed with flat washers, lock washers, and nuts.

For Installation Assistance or Technical Help, Call 1-888-521-0510

**Note:** On vehicles with heavy duty suspensions, check for interference with bolts where brackets are mounted to frame. If interference with suspension spring results, cut bolt flush to nut outboard of frame or use weld option.

**⚠ WARNING:**  
DO NOT lubricate threads. It may cause bolt failure.

**⚠ CAUTION:** ⚠  
Check for obstructions before drilling. Failure to do so could result in damaged fuel or brake lines, structural members, etc. CEQUENT TOWING PRODUCTS does its best to communicate tow vehicle manufacturer changes; however, it is ultimately the responsibility of the installer to prevent damage due to installation.

**⚠ CAUTION:** ⚠  
It is important that 17/32" drill be used for holes in chassis frame as rib neck bolts may break if too small a hole is used and neck may not grip if too large a hole is used.

11. Torque all nuts to 75 lb-ft
12. Pull wire provided to pull bolts through frame as needed per application

### Drill locations will vary. See individual installation for location

**Fig. 2**

Use side bracket/hitch base assembly to position rails (not included)

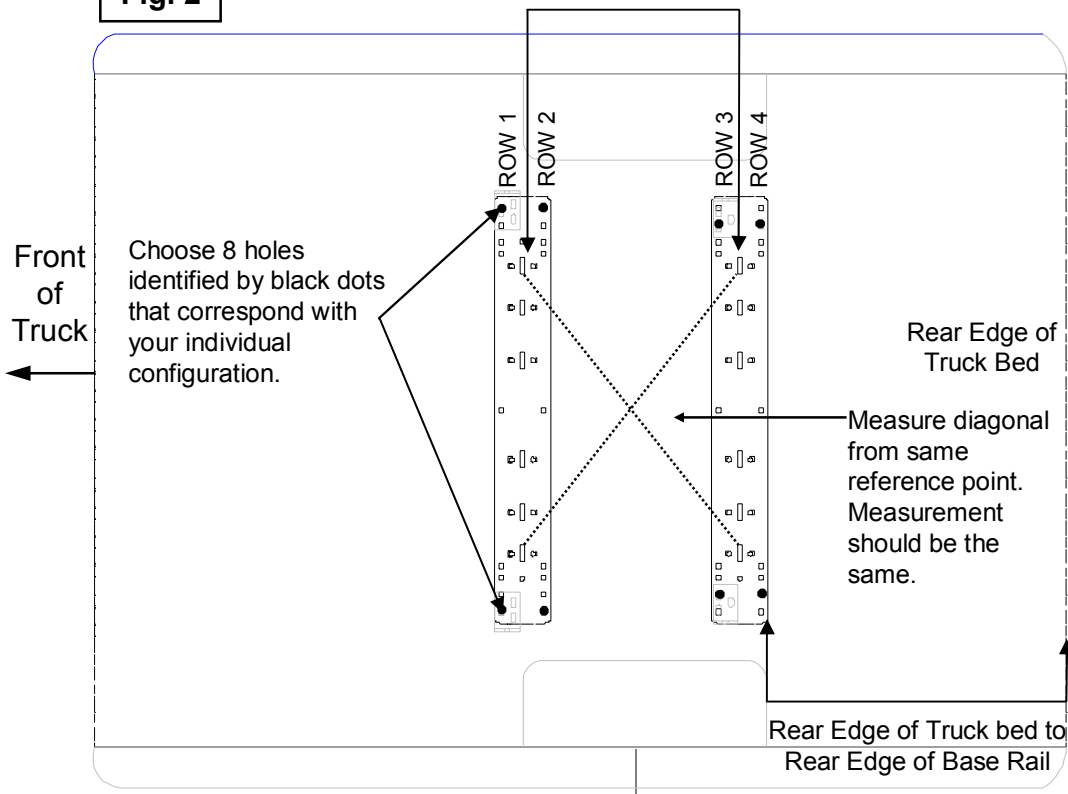

# Ford '04 & UP F-150, 5.5', 6', & 8' BEDS

## ⚠ CAUTION! ⚠

Read pages 2-3 of Base Rail instructions before starting installation. Failure to do so could result in significant vehicle damage!

### IMPORTANT NOTES FOR THIS INSTALLATION:

1. Do not drill through both walls of frame. Drill only through wall of frame to which bracket is mounted.
2. Find parallel rows of bed sill spot welds in bed of truck. No drilling should be done in the ~4" between parallel rows of spot welds where the bed sill sits.
3. Remove jounce block from bottom of frame on both sides.
4. When brackets are in place one of the front 2 holes should line up with a hole in the frame. A hole will need to be drilled in the frame at the rearward bracket hole.
5. Pull carriage bolts with bolt plates (using supplied pull wire) through the hole in the bottom of frame (where the jounce block was removed) and through the rear hole in each bracket. On the forward brackets a carriage bolt, bolt plate and a 1" washer should be pulled through the forward hole, rearward brackets a carriage bolt, bolt plate and 13/16" washer.

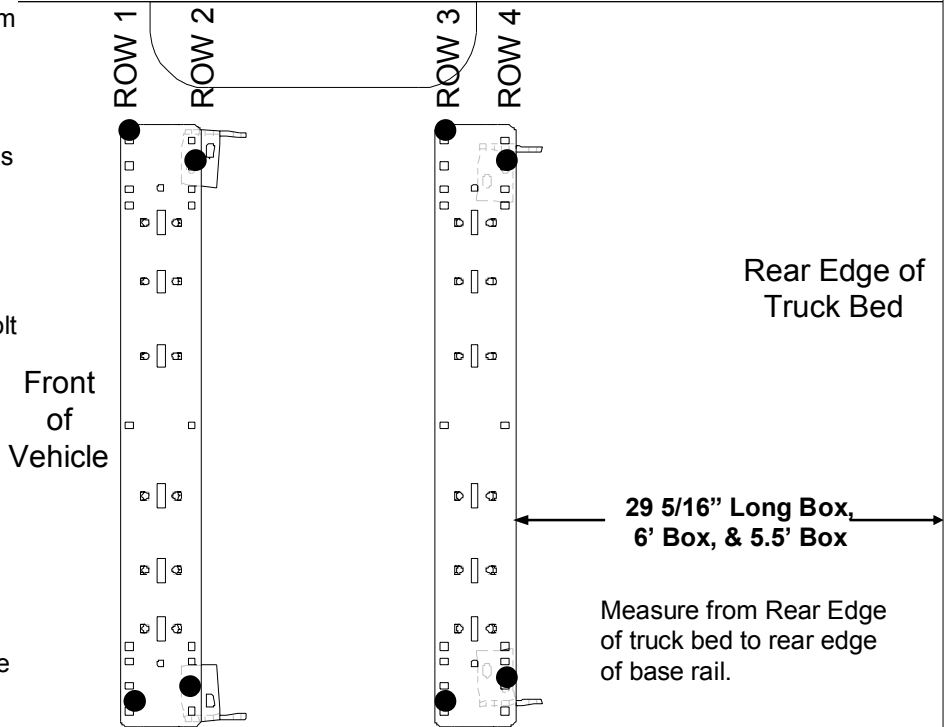

6. Replace the jounce block.

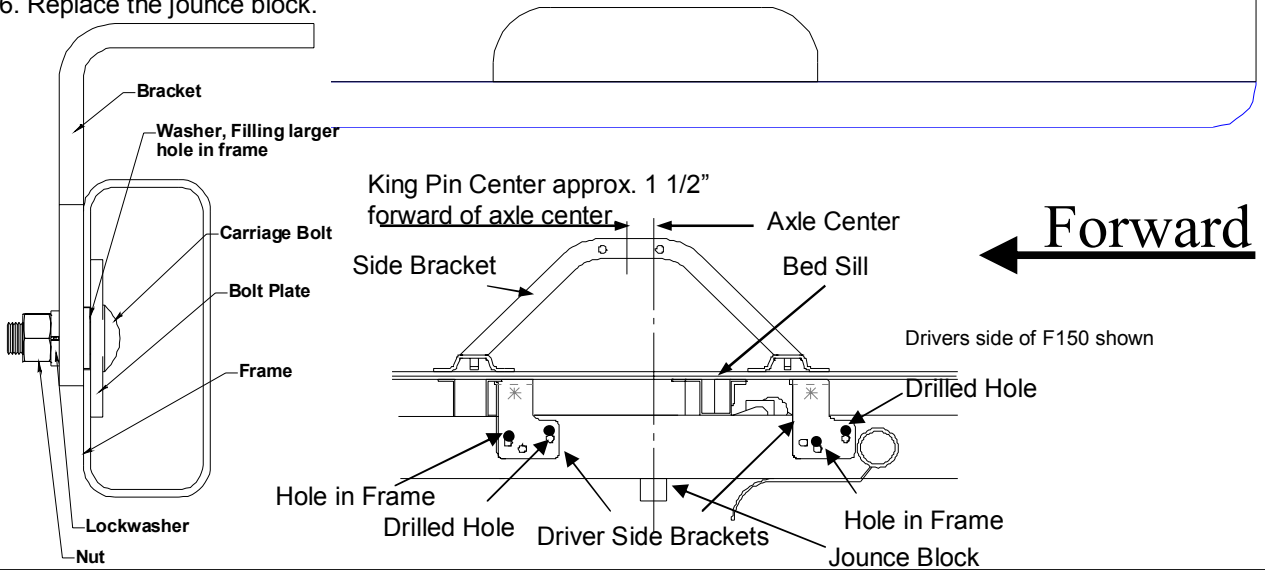

## ⚠ CAUTION! ⚠

Check for obstructions before drilling. Failure to do so could result in damaged fuel or brake lines, structural members, etc. CEQUENT TOWING PRODUCTS does its best to communicate tow vehicle manufacturer changes; however, it is ultimately the responsibility of the installer to prevent damage due to installation.

# NOTES

## **FIVE YEAR LIMITED WARRANTY**

### **Hitches - Custom Receivers**

Cequent Towing Products warrants its 5th Wheel Hitch Mounting Kits from date of purchase against defects in material and workmanship under normal use and service, ordinary wear and tear excepted, for 5 years of ownership to the original consumer purchaser when a Reese mounting kit is used.

Cequent Towing Products will replace FREE OF CHARGE any part which proves defective in material or workmanship when presented to any Reese dealer, Reese Warehouse or returned to factory. TRANSPORTATION CHARGES PREPAID, at the address below. THIS WARRANTY IS LIMITED TO DEFECTIVE PARTS REPLACEMENT ONLY. LABOR CHARGES AND/OR DAMAGE INCURRED IN INSTALLATION OR REPLACEMENT AS WELL AS INCIDENTAL AND CONSEQUENTIAL DAMAGES CONNECTED THEREWITH ARE EXCLUDED.

Some states do not allow the exclusion or limitation of incidental or consequential damages, so the above limitation or exclusion may not apply to you.

Any damage to the 5th Wheel Hitch as a result of misuse, abuse, neglect, accident, improper installation, or any use violative of instructions furnished by us, WILL VOID THE WARRANTY.

This warranty gives you specific legal rights, and you may also have other rights which vary from state to state. In the event of a problem with warranty service or performance, you may be able to go to a small claims court, or a federal district court.

Cequent Towing Products, Inc.  
47774 Anchor Court W.  
Plymouth MI 48170