

INSTALLATION INSTRUCTIONS

EQUIPMENT REQUIRED: NONE

WIRING ACCESS LOCATION: PC1, PC2

DRILL BITS: 1/2

HITCH REQUIRES 1/2" PIN & CLIP

WRENCHES: (TIGHTEN ALL FASTENERS WITH TORQUE WRENCH) 10mm, 11/16, 3/4

VEHICLE	HITCH NO.
MITSUBISHI LANCER	24718 77032 60866

2000 LB MAX GROSS TRAILER WT
200 LB MAX TONGUE WEIGHT
DO NOT EXCEED TOWING VEHICLE RATINGS

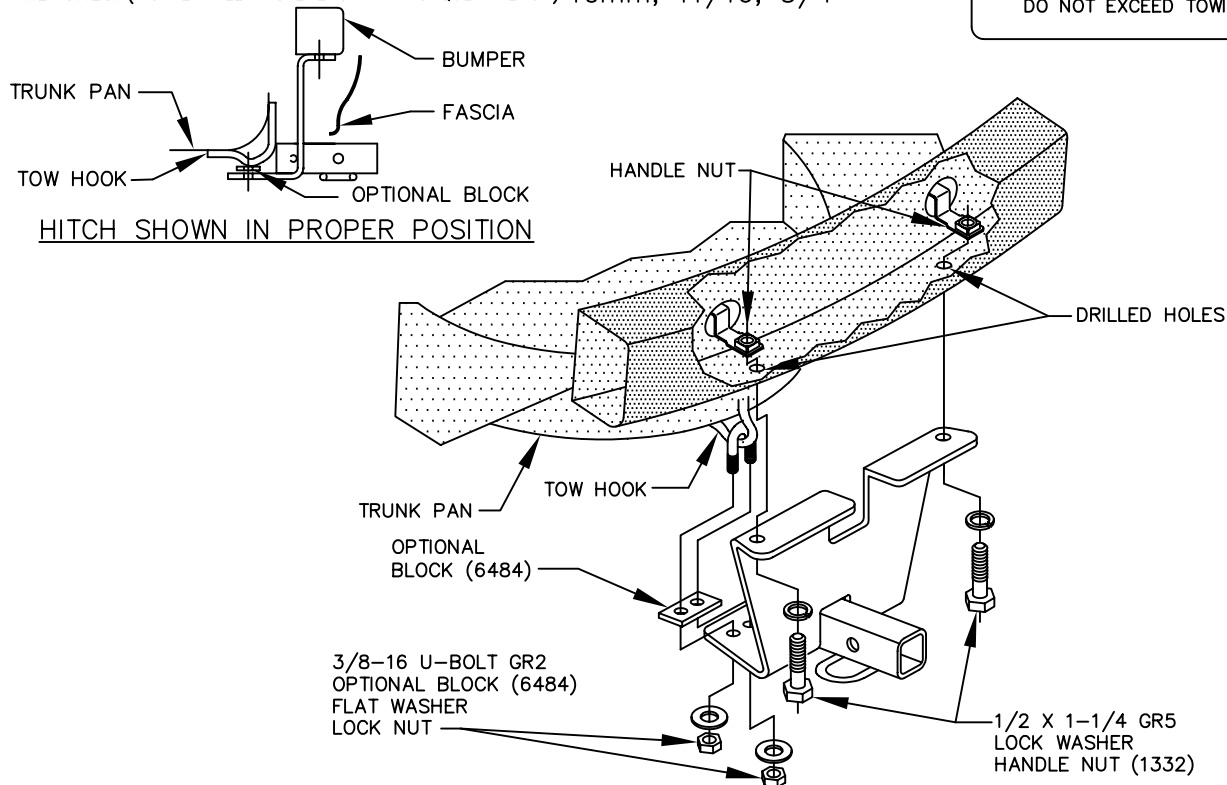

NOTE: ON SOME MODELS WHICH HAVE DUAL PLASTIC FASCIAS, IT MAY BE NECESSARY TO REMOVE LOWER FASCIA FROM UPPER FASCIA BY REMOVING (3) BOLTS WHICH HOLD THE FASCIAS TOGETHER.

1. RAISE HITCH INTO POSITION CENTERED ON VEHICLE, SLIDING HITCH FORWARD ON VEHICLE UNTIL RECEIVER TUBE CONTACTS TOW HOOK.
2. WITH HITCH IN POSITION, MARK LOCATIONS OF HOLES IN HITCH BRACKET ON VEHICLE BUMPER, LOWER HITCH.
3. DRILL 1/2" HOLES IN VEHICLE BUMPER AT LOCATIONS MARKED IN STEP 2.
4. RAISE HITCH BACK INTO POSITION. INSTALL 1/2" FASTENERS AS SHOWN IN FIGURE 1.
5. INSTALL 3/8" U-BOLT THROUGH TOW HOOK AND HITCH BRACKET AS SHOWN ABOVE. USE BLOCK (6484) IF NEEDED SO THAT RECEIVER IS LEVEL OR TILTED SLIGHTLY FORWARD. FASTEN WITH FLAT WASHERS AND NUTS AS SHOWN. MAKE SURE FLAT WASHERS DO NOT OVERLAP.

TIGHTEN 3/8 GR2 FASTENERS TO 20 LB.-FT.

TIGHTEN 1/2 GR5 FASTENERS TO 75 LB.-FT.

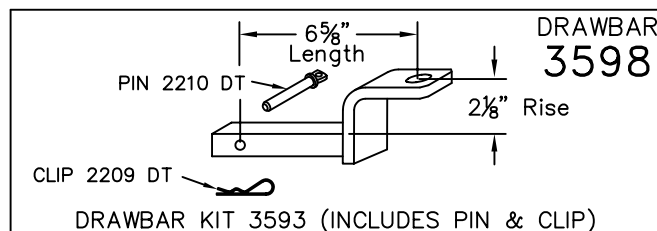

USE ONLY THE DRAWBAR SHOWN FOR CORRECT BUMPER CLEARANCE AND HEIGHT.
DRAWBAR MUST BE USED IN THE RISE POSITION ONLY.

THIS PRODUCT COMPLIES WITH SAFETY SPECIFICATIONS AND REQUIREMENTS FOR CONNECTING DEVICES AND TOWING SYSTEMS OF THE STATE OF NEW YORK AND V.E.S.C. REGULATION V-5.

APPROX WEIGHT (LB.)	FASTENER KIT
12	F24718

NOTE: Check hitch frequently, making sure all fasteners and ball are properly tightened. If hitch is removed, plug all holes in trunk pan or other body panels to prevent entry of water and exhaust fumes. A hitch or ball which has been damaged should be removed and replaced. Observe safety precautions when working beneath a vehicle and wear eye protection. Follow car maker's specs for maximum trailer weight and tongue weight. Do not cut access or attachment holes with a torch.

TOWING PRODUCTS
Plymouth, Michigan